

MEMORANDUM

TO: File No. SR-NASDAQ-2023-016

FROM: David Remus, Office of Market Supervision, Division of Trading and Markets

DATE: November 28, 2023

SUBJECT: Meeting with BlackRock, Inc. re: iShares Bitcoin Trust

On November 28, 2023, Eric Juzenas, Randall Roy, Ray Lombardo, Molly Kim, Edward Cho, Sarah Schandler, Stacia Sowerby, and David Remus, from the Division of Trading and Markets, participated in a meeting with the following individuals:

Robert Mitchnick, BlackRock, Inc.
Adithya Attawar, BlackRock, Inc.
Shannon Ghia, BlackRock, Inc.
Charles Park, BlackRock, Inc.
Marisa Rolland, BlackRock, Inc.
Ben Tecmire, BlackRock, Inc.
Jonathan Cayne, The NASDAQ Stock Market LLC
Giang Bui, The NASDAQ Stock Market LLC
Ali Doyle, The NASDAQ Stock Market LLC

The discussion concerned The NASDAQ Stock Market LLC's proposed rule change to list and trade shares of the iShares Bitcoin Trust under NASDAQ Rule 5711(d). Blackrock also provided the attached presentation.

Revised In-Kind Model Design

Background: During our 11/20 meeting with Trading & Markets staff, we understood the SEC has certain unresolved questions around the In-kind model relating to balance sheet impacts and risks to the Market Maker’s U.S. Registered Broker/Dealer entity (“MM-BD”, as distinct from the Market Maker’s unregistered entity (“MM-crypto”)) during the redemption flow.

Solution: We would like to propose the following approach, that we believe would resolve these concerns:

Current In-kind Redemption flow	Revised In-kind (“Prepay Model”) Redemption flow
<p>T:</p> <ol style="list-style-type: none"> 1) MM-BD places redemption order through AP 2) Issuer approves order 3) MM-crypto borrows bitcoin (or cash) to sell short bitcoin (or bitcoin futures) 	<p>T:</p> <ol style="list-style-type: none"> 1) MM-BD places redemption order through AP 2) Issuer approves order 3) MM-crypto borrows bitcoin (or cash) to sell short bitcoin (or bitcoin futures)
<p>T+1:</p> <ol style="list-style-type: none"> 4) MM-BD delivers ETF shares to Transfer Agent via AP 5) Issuer instructs Bitcoin Custodian to transfer bitcoin to MM-crypto 6) MM-crypto closes short position in bitcoin 	<p>T+1:</p> <ol style="list-style-type: none"> 4) MM-crypto delivers cash to MM-BD 5) MM-BD delivers ETF shares to Transfer Agent via AP¹ 6) Issuer instructs bitcoin custodian to transfer bitcoin to MM-crypto 7) MM-crypto closes short position in bitcoin

Benefits: This model appears to address the Staff’s concern with In-kind, addressing the critical dimension on which the In-kind model would otherwise be not preferred to the Cash model. In so doing, it preserves the many significant benefits to investors of the In-kind model over certain Cash models in the context of bitcoin, including:

- i. Lower transaction costs
- ii. Execution risks borne by crypto market makers instead of investors
- iii. Superior resistance to market manipulation
- iv. Removal of need for issuers to finance or pre-fund sell trades
- v. Reduction in risks of operating events
- vi. Simplicity and harmonization across the ecosystem given significantly lower variance on how In-kind models can be executed vs. Cash models

¹ If MM-crypto does not successfully deliver cash to MM-BD at EOD on T, order can be cancelled by AP.

Balance Sheet Analysis²

REVISED IN-KIND (“PREPAY MODEL”)

Before order:

MM-BD	
Assets	Liabilities
ETF shares	

MM-crypto	
Assets	Liabilities

After order:

MM-BD	
Assets	Liabilities
Cash receivable (from MM-crypto)	ETF shares deliverable
ETF shares	

MM-crypto	
Assets	Liabilities
Cash	Bitcoin deliverable (to a lender)
Bitcoin receivable (from Trust)	Cash deliverable (to MM-BD)

- 1) MM-BD places redemption order through AP
- 2) Issuer approves order
- 3) MM-crypto borrows bitcoin to sell short

AM on T+1:

MM-BD	
Assets	Liabilities
Cash	ETF shares deliverable
ETF shares	

MM-crypto	
Assets	Liabilities
Bitcoin receivable (from Trust)	Bitcoin deliverable (to a lender)

- 4) MM-crypto delivers cash to MM-BD prior to ETF shares being delivered

After redemption settlement (PM on T+1):

MM-BD	
Assets	Liabilities
Cash	

MM-crypto	
Assets	Liabilities
Bitcoin	Bitcoin deliverable (to a lender)

- 5) MM-BD delivers ETF shares to Transfer Agent via AP
- 6) Issuer instructs Bitcoin Custodian to transfer bitcoin to MM-crypto

At EOD on T+1:

MM-BD	
Assets	Liabilities
Cash	

MM-crypto	
Assets	Liabilities

- 7) MM-crypto closes short position in bitcoin

² Modifications made to reflect discussion.

CASH MODEL^{3,4}

Before order:

MM-BD	
Assets	Liabilities
ETF shares	

MM-crypto	
Assets	Liabilities

After order:

MM-BD	
Assets	Liabilities
Cash receivable (from Trust)	
ETF shares	ETF shares deliverable

MM-crypto	
Assets	Liabilities
Cash	Bitcoin deliverable (to a lender)
Bitcoin receivable (from Trust)	Cash deliverable (to Trust)

- 1) MM-BD places redemption order through AP
- 2) Issuer approves order
- 3) MM-crypto borrows bitcoin to sell short
- 4) Issuer instructs Bitcoin Custodian to move bitcoin out of Cold storage
- 5) Issuer enters trade with MM-crypto to sell bitcoin for USD

After redemption settlement (PM on T+1):

MM-BD	
Assets	Liabilities
Cash	

MM-crypto	
Assets	Liabilities
Bitcoin	Bitcoin deliverable (to a lender)

- 6) MM-crypto delivers cash to Issuer's Transfer Agent
- 7) Bitcoin Custodian delivers bitcoin to MM-crypto to settle
- 8) MM-BD delivers ETF shares to Transfer Agent via AP
- 9) Issuer delivers cash to MM-BD via AP

At EOD on T+1:

MM-BD	
Assets	Liabilities
Cash	

MM-crypto	
Assets	Liabilities

- 10) MM-crypto closes short position in bitcoin

³ Note: MM-BD balance sheet at all points in proposed Prepay model the same or stronger than in Cash model.

⁴ Reflects one illustrative Cash model. There are a large number of variations in how Cash model can be executed.

Original In-Kind Redemption Model

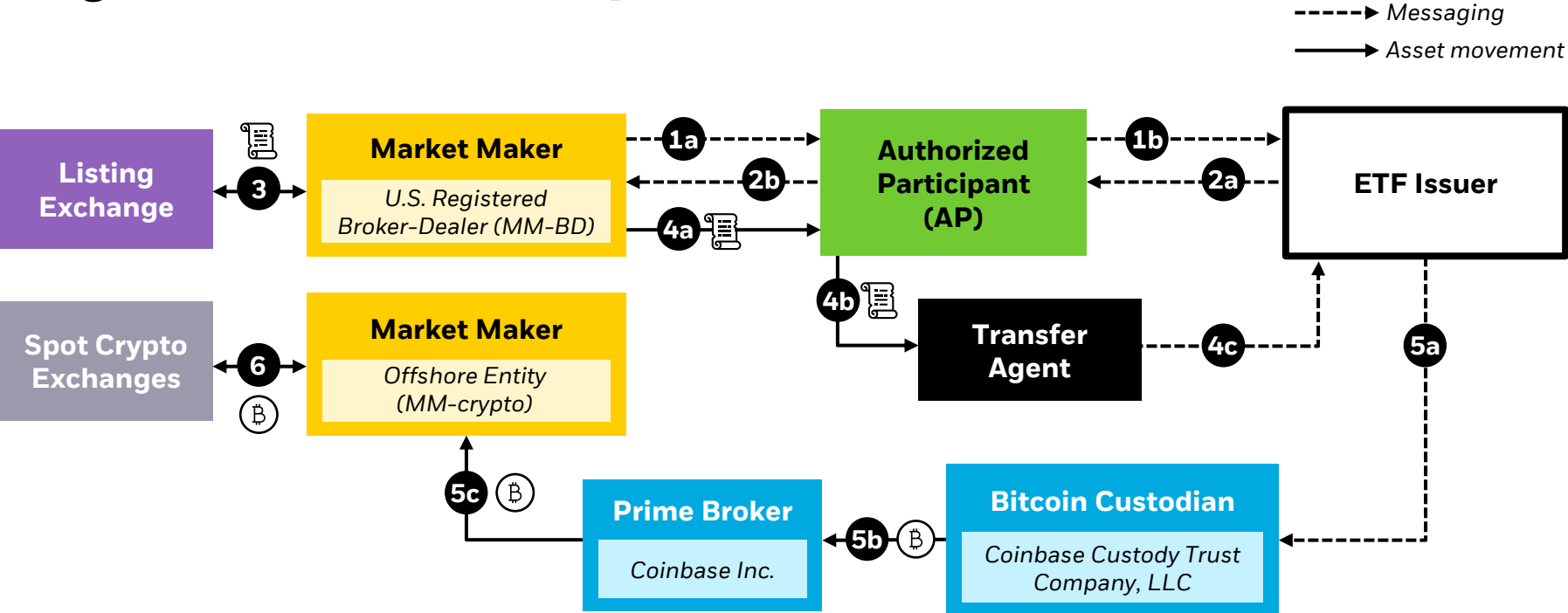

Redemption lifecycle

T:

- 1** Market Maker (MM-BD) places redemption order via Authorized Participant (AP) in response to ETF dislocation from NAV
- 2** ETF Issuer approves redemption order
- 3** MM-BD buys ETF shares via Listing Exchange

T+1:

- 4** MM-BD delivers ETF shares to Transfer Agent
- 5** ETF Issuer instructs Bitcoin Custodian to release bitcoin to MM-crypto via transfer through Prime Broker
- 6** MM-crypto may unwind bitcoin position

For illustrative purposes only. May not reflect all steps involved in process by all parties.

Revised In-Kind (“Prepay”) Redemption Model

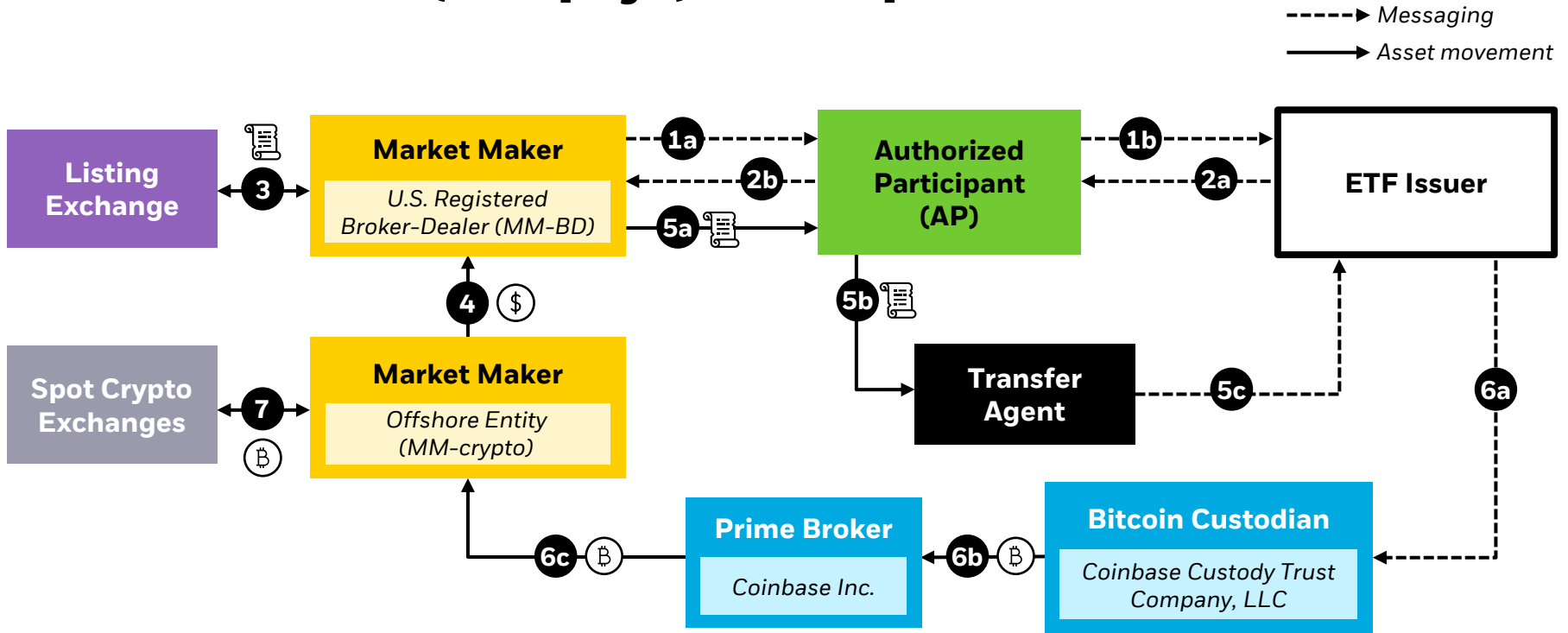

Redemption lifecycle

T:

- 1** Market Maker (MM-BD) places redemption order via Authorized Participant (AP) in response to ETF dislocation from NAV
- 2** ETF Issuer approves redemption order
- 3** MM-BD buys ETF shares via Listing Exchange

T+1:

- 4** MM-crypto delivers cash to MM-BD
- 5** MM-BD delivers ETF shares to Transfer Agent
- 6** ETF Issuer instructs Bitcoin Custodian to release bitcoin to MM-crypto via transfer through Prime Broker
- 7** MM-crypto may unwind bitcoin position

For illustrative purposes only. May not reflect all steps involved in process by all parties.

Cash Redemption Model

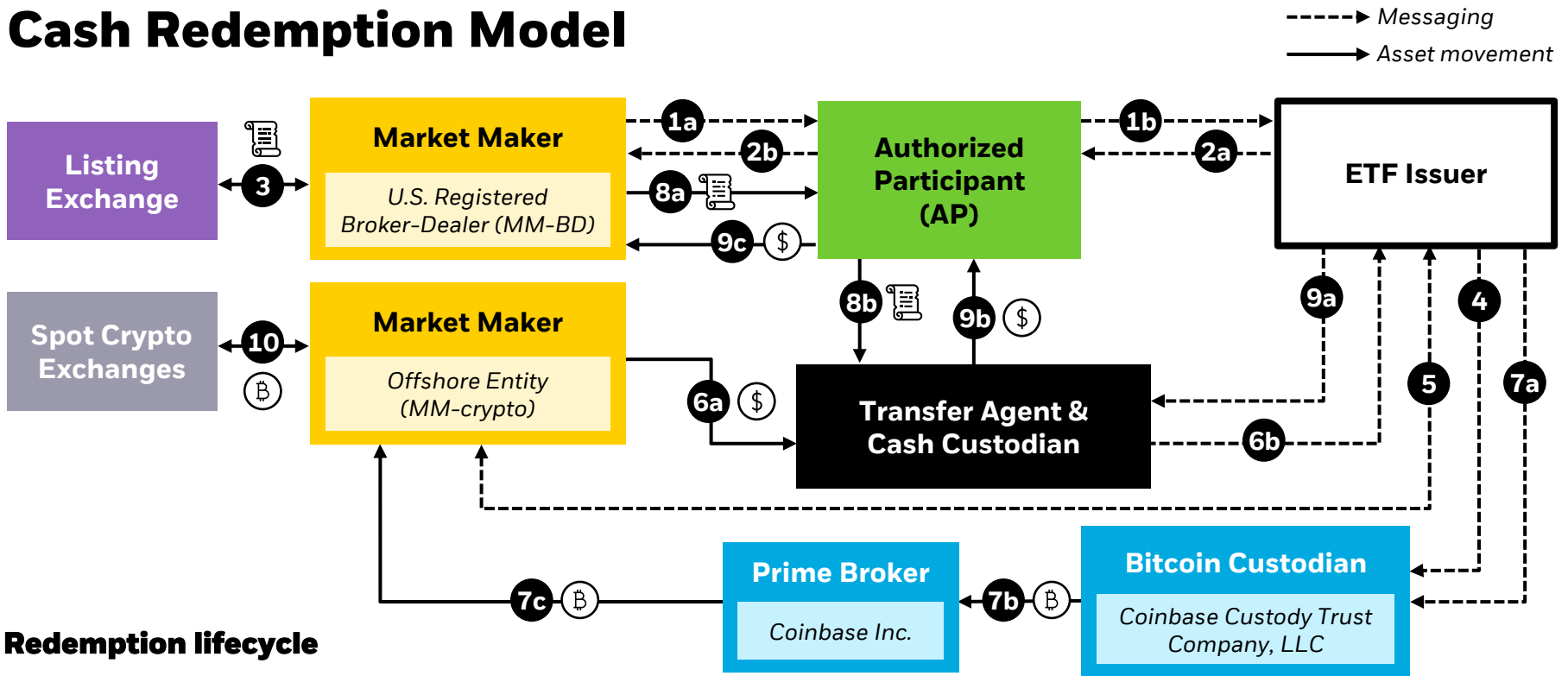

Redemption lifecycle

T:

- 1** Market Maker (MM-BD) places redemption order via Authorized Participant (AP) in response to ETF dislocation from NAV
- 2** ETF Issuer approves redemption order
- 3** MM-BD buys ETF shares via Listing Exchange
- 4** ETF Issuer instructs Bitcoin Custodian to move bitcoin out of cold storage so it can be sold
- 5** ETF Issuer enters trade with MM-crypto to sell bitcoin for USD

T+1:

- 6** MM-crypto delivers cash to Transfer Agent
- 7** Bitcoin Custodian delivers bitcoin to MM-crypto via transfer through Prime Broker
- 8** MM-BD delivers shares to Transfer Agent via AP
- 9** ETF Issuer instructs Cash Custodian to release cash to MM-crypto via AP
- 10** MM-crypto may unwind bitcoin position

For illustrative purposes only. May not reflect all steps involved in process by all parties. Reflects only one possible Cash model; the number of possible approaches to Cash are significantly more varied, with more complex distinctions, than the number of possible approaches to In-kind. Other Cash models may reflect significant differences.